

NOTE: DO NOT OVER-DRIVE FASTENERS. IF THE METAL AT THE EDGE OF THE PANEL IS DEFORMED OUT OF PLANE, THE ADJACENT PANEL WILL BE DIFFICULT TO ENGAGE AND WILL NOT SEAM. AFTER SR CLIP HAS BEEN INSTALLED IN PLACE OVER MALE LEG OF STANDING SEAM PANEL, PRE-CRIMP USING 1/2" HAND CRIMPING TOOL.

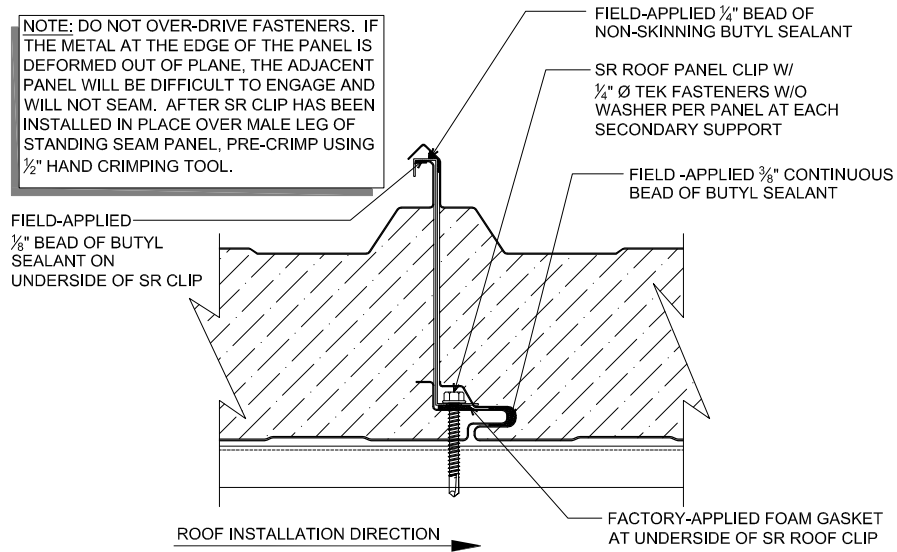

SR ROOF PANEL JOINT
(SECTION VIEW)

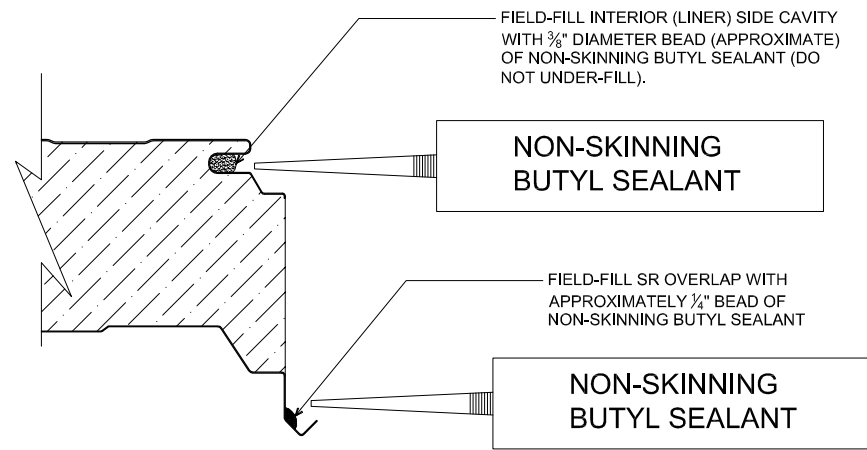

SEALANT PLACEMENT AT PANEL JOINT

DETAIL:

PANEL JOINT

APPLICATION:

SR ROOF, COMMERCIAL & INDUSTRIAL, COLD-STORAGE, COLD-CLIMATE

AWIP DETAIL NUMBER:

SRR-CICSCC-P-J-001

DATE:

04/28/22

DRAWN BY:

MMF

SHEET:

1

OF

1

929 ALDRIDGE ROAD
VACAVILLE, CA 95688
TEL: (707) 359-2280
FAX: (707) 359-2286
WWW.AWIPANELS.COM

