

**EAVE PREPARATION**  
(ISOMETRIC VIEW)

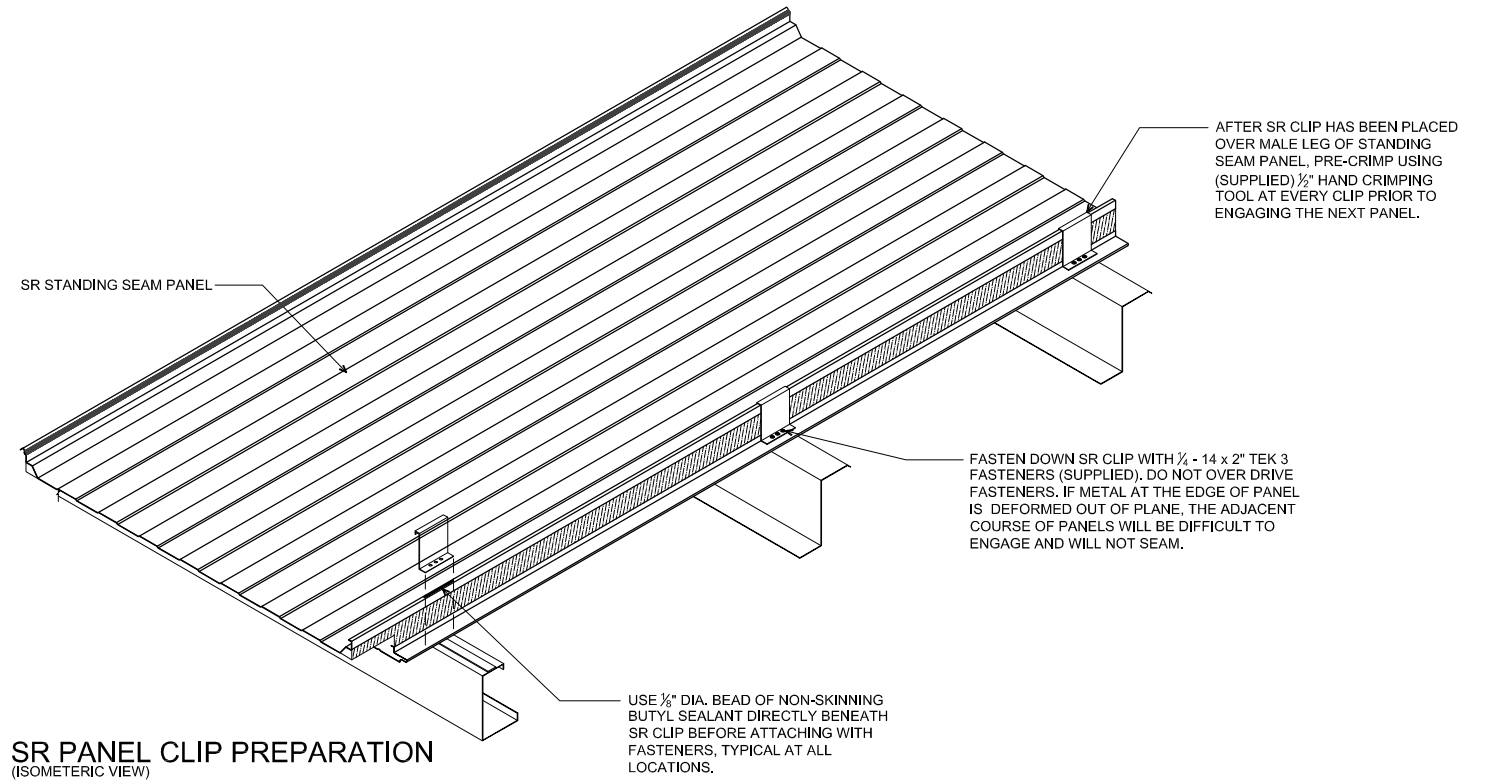

**SR PANEL CLIP PREPARATION**  
(ISOMETRIC VIEW)

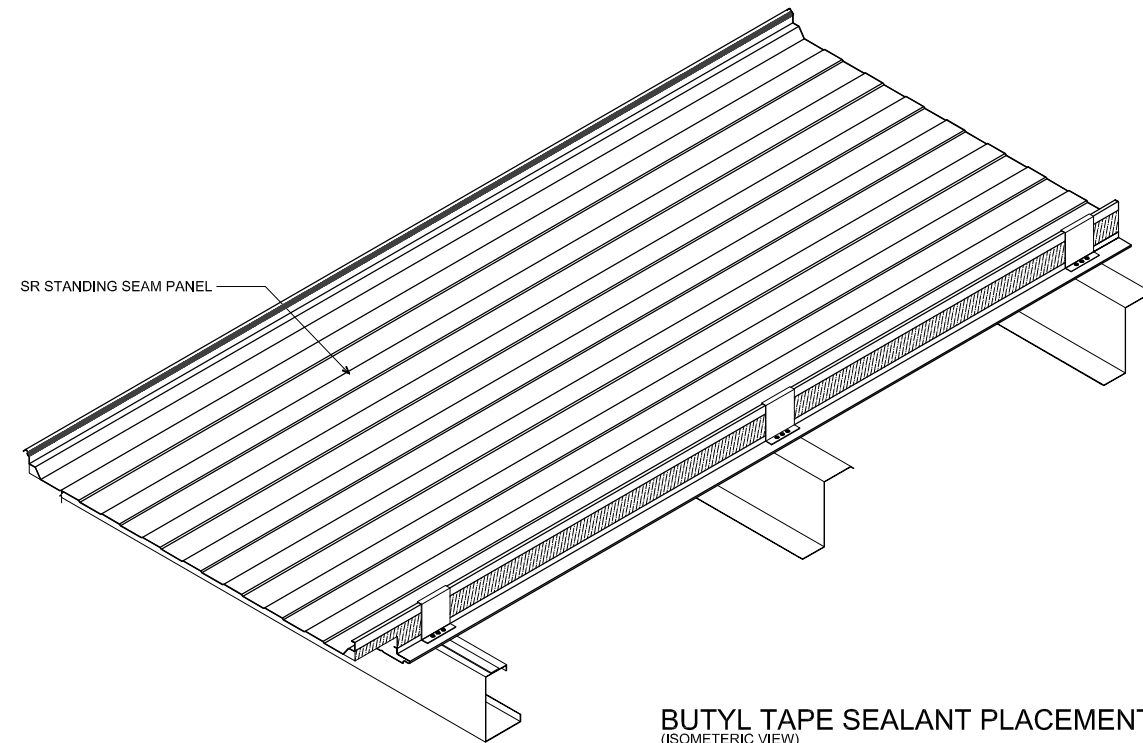

**BUTYL TAPE SEALANT PLACEMENT**  
(ISOMETRIC VIEW)

DETAIL:

**ISOMETRIC - SINGLE-COURSE**

APPLICATION:  
SR ROOF, COMMERCIAL & INDUSTRIAL  
AWIP DETAIL NUMBER:  
SRR-ACHISO-001

929 ALDRIDGE ROAD  
VACAVILLE, CA 95688  
TEL: (707) 359-2280  
FAX: (707) 359-2286  
WWW.AWIPANELS.COM



DATE: 06/26/20  
DRAWN BY: MMF

SHEET: 1

OF 1