

fiRe WALL PANELS

GENERAL INSTALLATION GUIDE



All Weather
Insulated Panels

929 ALDRIDGE ROAD
VACAVILLE, CA 95688
PHONE: (707) 359-2280
FAX: (707) 359-2286
WWW.AWIPANELS.COM

GENERAL INSTALLATION GUIDE

DISCLAIMER:

ALL WEATHER INSULATED PANELS (AWIP) SHALL NOT BE RESPONSIBLE FOR ANY DAMAGE AND INJURIES INCURRED WHILE HANDLING AND/OR INSTALLING THE PANELS, TRIM AND ACCESSORIES. ON-SITE PERSONNEL SHALL FOLLOW THE APPROPRIATE SAFETY PROTOCOLS AS DETERMINED BY THE RELEVANT GOVERNING BODIES.

PLEASE REFER TO PROJECT-SPECIFIC DETAILS IS ALL WEATHER INSULATED PANELS HAS PROVIDED SHOP / ERECTION DRAWINGS. SHOP DRAWINGS PREPARED BY AWIP SHOW FASTENING DETAILS, PANEL LAYOUTS, WALL ELEVATIONS, ROOF PLANS AND / OR CEILING PLANS ONLY AND REFLECT THE DESIGN CRITERIA LISTED ON THE COVER PAGE. THE SHOP DRAWINGS ARE INTENDED TO BE A GUIDE FOR MINIMUM ACCEPTABLE INSTALLATION PROCEDURES AND TO INDICATE THE QUANTITY, SIZE AND MATERIAL SPECIFICATIONS OF PRODUCTS FURNISHED BY AWIP FOR THE REFERENCED PROJECT. THEY DO NOT REPLACE OR SUPPLANT SPECIFICATIONS OR NOTES ON STRUCTURAL DRAWINGS. IT IS THE **CUSTOMER'S** RESPONSIBILITY TO VERIFY AND APPROVE THE DESIGN LOADS SHOWN ON THE AWIP SHOPS DRAWINGS **AND / OR** PROVIDE AWIP WITH ANY ADDITIONAL DESIGN LOADS THAT NEED TO BE TAKEN INTO CONSIDERATION.

AWIP IS ONLY RESPONSIBLE FOR SHOWING AND PROVIDING MATERIALS THAT ARE INCLUDED IN THE SALES ORDER ACKNOWLEDGEMENT. THE MATERIALS FURNISHED BY AWIP HAVE BEEN APPROVED FOR THE PURPOSES SHOWN IN THE AWIP SHOP DRAWINGS. MATERIALS NOT PROVIDED BY AWIP MAY BE SHOWN IN THE AWIP SHOP DRAWINGS FOR INFORMATIONAL OR CLARITY PURPOSES. THE AWIP SHOP DRAWINGS ARE BASED OFF INFORMATION PROVIDED TO THE AWIP DETAILING TEAM. DETAILS AND DIMENSIONS MUST BE VERIFIED BY THE **CUSTOMER**. AWIP SHALL NOT BE RESPONSIBLE OR LIABLE FOR INCORRECT DIMENSIONS OR CONDITIONS AFTER SIGNED APPROVED SHOP DRAWINGS ARE RETURNED.

UNLESS NOTED OTHERWISE, THIS PROJECT HAS BEEN DESIGNED BASED ON **AMBIENT BUILDING** CONDITIONS AND NOT AS A COOLER OR FREEZER BUILDING. IF THIS IS NOT THE CASE, PLEASE NOTIFY YOUR AWIP PROJECT MANAGER IMMEDIATELY AND PROVIDE THE INTERIOR TEMPERATURE(S).

SHEET:

2 OF 11

DATE:

06/14/22

DRAWN BY:

MMF

fIRE WALL PANELS GENERAL INSTALLATION GUIDE

HANDLING INSTRUCTIONS:

1.0 ARRIVAL ON SITE

- 1.1 ALL WEATHER INSULATED PANELS ARE CAREFULLY BUNDLED AND STRETCH-WRAPPED TO PREVENT DAMAGE DURING SHIPPING. THE TRANSPORTATION COMPANY IS RESPONSIBLE FOR DELIVERING THESE COMPONENTS UNDAMAGED. FREIGHT CLAIMS SHOULD BE HANDLED DIRECTLY WITH THE FREIGHT COMPANY.
- 1.2 WHEN SHIPMENT IS RECEIVED, CHECK EACH ITEM AGAINST THE BILL OF LADING FOR QUANTITY, LENGTH, TRANSIT DAMAGE, ETC. IF SHORTAGE OR DAMAGE IS FOUND, MAKE SURE A NOTATION OF IT IS MADE ON THE BILL OF LADING AND SIGNED BY THE DRIVER. IT IS THE CUSTOMER'S RESPONSIBILITY TO MAKE ANY DAMAGE CLAIM(S).
- 1.3 PLEASE NOTIFY ALL WEATHER INSULATED PANELS OF ANY ORDER DISCREPANCIES WITHIN 72 HOURS OF DELIVERY. OTHERWISE, ALL WEATHER INSULATED PANELS WILL CONCLUDE THAT THE ORDER WAS COMPLETED SUCCESSFULLY.
- 1.4 A PANEL PACKING LIST IS PROVIDED FOR EACH BUNDLE AND IS LOCATED WITHIN A SLEEVE ADHERED TO THE SIDE WRAPPING. PLEASE USE THIS DOCUMENT TO CHECK FOR BUNDLE INFORMATION.
- 1.5 ALL WEATHER INSULATED PANELS WILL GENERALLY ARRIVE IN LARGE, STRETCH-WRAPPED BUNDLES ON FLAT BED TRAILERS. CONSEQUENTLY, THE BUNDLES SHOULD BE OFF-LOADED BY MEANS OF CRANE SYSTEM OR FORKLIFT.

2.0 UNLOADING WITH A FORKLIFT

- 2.1 ALL PANEL BUNDLES ARE REINFORCED WITH BOTTOM SHEET(S) OF OSB AT LIFTING POINTS TO PREVENT DAMAGE DURING HANDLING. LIFT BUNDLES ONE AT A TIME WITH A FORKLIFT. SEE FIGURE 1 (BELOW) FOR RECOMMENDED LIFTING POINT LOCATIONS. LONG-LENGTH BUNDLES (36'-0" OR LONGER) WILL HAVE FOUR OR MORE LIFTING POINTS (SEE FIGURE 2, BELOW).
- 2.2 FORK BLADES MUST BE SET TO NOT LESS THAN 48" WIDE.
NOTE: ENSURE THAT FORKS ARE BETWEEN THE 3" FOAM STICKERS AT THE BOTTOM OF EACH BUNDLE.
- 2.3 DO NOT OVER-ENGAGE FORKS WHEN LIFTING A BUNDLE AS DOING SO MAY DAMAGE THE BUNDLE(S) BEHIND IT.
- 2.4 6" FOAM BLOCKS MAY BE PLACED ON THE BACK (UPRIGHT) LEG OF THE FORKS TO SOFTEN THE CONTACT BETWEEN THE FORKS AND THE BUNDLE.
- 2.5 CAUTION STICKERS ARE AFFIXED TO EITHER SIDE OF EACH BUNDLE AS A QUICK ON-SITE REFERENCE FOR OFF-LOADING.
NOTE: EXTREME CARE SHOULD BE TAKEN TO AVOID BUMPING THE PANELS WHEN LIFTING AND MANEUVERING.

3.0 UNLOADING WITH A CRANE

- 3.1 WHEN MOVING BUNDLE(S) WITH A CRANE, USE AN APPROPRIATE COMBINATION OF SPREADER BARS, SLINGS, AND ANTI-PINCH BOARDS TO SAFELY DISTRIBUTE THE BUNDLE'S WEIGHT. WHEN BUNDLES ARE LONGER THAN 15'-0", IT IS SUGGESTED THAT A PROPERLY DESIGNED AND FABRICATED LIFTING BEAM / SPREADER BAR IS USED.
- 3.2 ANTI-PINCH BOARDS SHOULD BE LONG ENOUGH TO SWALLOW THE ENTIRE WIDTH OF THE BUNDLE AND BE PLACED AT THE TOP AND BOTTOM OF THE BUNDLE. USE ONE SET (TOP AND BOTTOM) OF ANTI-PINCH BOARDS PER SLING.
- 3.3 THE SIZE AND QUANTITY OF THE SPREADER BAR(S) MAY VARY DEPENDING ON THE LENGTH AND WEIGHT OF THE BUNDLE(S). LONG-LENGTH BUNDLES (36'-0" OR LONGER) WILL HAVE FOUR OR MORE LIFTING POINTS (SEE FIGURE 2, BELOW).
- 3.4 ONLY LIFT ONE BUNDLE AT A TIME.

"STANDARD-LENGTH" BUNDLES (10'-0" OR LONGER)

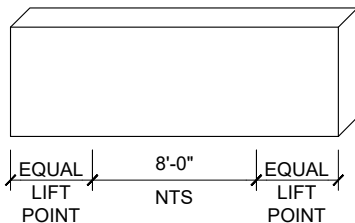

USE ONE FORKLIFT TO LIFT BUNDLES AT THE LIFT POINT SECTIONS.

FIGURE 1

"LONG-LENGTH" BUNDLES (36'-0" OR LONGER)

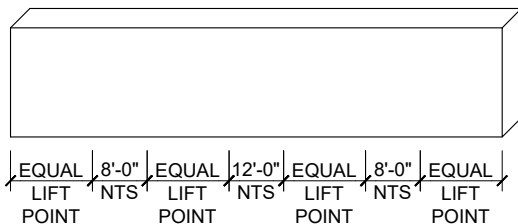

WHEN HANDLING LONG-LENGTH BUNDLES, BE CAREFUL NOT TO POSITION YOUR LIFT AT THE CENTER OF THE BUNDLES AS THIS MAY DAMAGE THE PANELS. USE TWO FORKLIFTS (OR CRANE STRAPS) TO LIFT BUNDLE AT THE LIFT POINT SECTIONS.

FIGURE 2

SHEET:

3 OF 11

DATE:

06/14/22

DRAWN BY:

MMF

**fiRe WALL PANELS
GENERAL INSTALLATION GUIDE**



4.0 MANUALLY UNLOADING

4.1 ON SMALL PROJECTS, UNLOADING OF THE PANELS MAY BE DONE BY HAND.

NOTE: SPECIAL CARE SHOULD BE TAKEN WHEN HANDLING PANELS. ALWAYS LIFT THE PANELS WHEN REMOVING FROM A BUNDLE, NEVER DRAG THEM.

4.2 AVOID CARRYING THE PANEL FROM A FLAT ORIENTATION, ESPECIALLY LONG PANELS WHICH ARE MORE PRONE TO BENDING DAMAGE. IF NECESSARY, USE MORE THAN TWO PERSONNEL TO EVENLY SUPPORT THE PANEL.

4.3 TO PREVENT JOINT DAMAGE, NEVER LIFT THE PANEL FROM THE FLAT POSITION BY THE SIDE JOINT OR THE OVERLAPPING RIB. DOING SO MAY CAUSE THE METAL AND FOAM TO SEPARATE.

NOTE: ALL PERSONNEL PERFORMING THESE TASKS MUST WEAR PROPER CLOTHING AND PROTECTIVE EQUIPMENT AT ALL TIMES.

STORAGE INSTRUCTIONS:

5.0 SITE STORAGE

5.1 IF THE PANELS ARE TO BE USED IMMEDIATELY, THE BUNDLES SHOULD BE PLACED AT THE PRE-PLANNED LOCATIONS AROUND THE PERIMETER OR THE BUILDING, AS CLOSE AS POSSIBLE TO THE CORRESPONDING WORK AREAS. PLACE BUNDLES AS FAR PRACTICAL FROM THE SITE TO AVOID POSSIBLE DAMAGE FROM LATER SITE MANEUVERING OR UNDUE HANDLING.

5.2 IDEALLY, THE BUNDLES SHOULD BE STORED UNDER A TEMPORARY SHELTER WITH THE PLASTIC REMOVED FROM THE TOP AND SIDES OF THE BUNDLE. SITE STORAGE TIME SHOULD BE MINIMIZED.

5.3 IF THE BUNDLES CANNOT BE STORED IN A COVERED LOCATION, IT IS NECESSARY TO CUT THE OUTSIDE PLASTIC WRAPPING AND ARRANGE THE BUNDLES SUCH THAT THEY ARE INCLINED AT A (MINIMUM) 1:12 SLOPE SUCH THAT WATER DOES NOT ACCUMULATE, AND MOISTURE BUILD UP BETWEEN PANELS IS AVOIDED. THE CONTINUOUS CUT SHOULD BE MADE ALONG THE WIDTH OF THE BUNDLE; CUT 1'-0" SLITS 5'-0" O/C ALONG THE LENGTH OF THE BUNDLE (SEE FIGURE 3, BELOW). DO NOT STORE FOR LONGER THAN 30 DAYS. MOISTURE BETWEEN PANELS CAN CAUSE CORROSION AND OXIDATION OF PAINTED SURFACES REFERRED TO AS "WET STACK".

NOTE: IF TEMPORARY SHELTER IS NOT AVAILABLE, OUR PANELS ARE PACKAGED WITH PLASTIC STRETCH WRAP AND EXPANDED POLYSTYRENE BOARD. IT IS, HOWEVER, A REQUIREMENT THAT ADDITIONAL PROTECTION BE PROVIDED TO PROTECT THE PANELS FROM WET WEATHER CONDITIONS DURING TRANSIT AND AT THE JOBSITE AS GYPSUM BOARD IS SUSCEPTIBLE TO MOISTURE ABSORPTION. STANDING WATER ON STORED AND/OR BUNDLED SKIDS MAY CAUSE DAMAGE TO THE PANEL FINISH AND IS NOT ACCEPTABLE.

NOTE: DO NOT STAND PANELS ON EDGE OF JOINERY OR SAW-CUT EDGE. NEVER STORE OR HANDLE PANELS IN A HORIZONTAL POSITION.

5.4 BUNDLES SHOULD BE STACKED NO MORE THAN TWO HIGH. THE FOAM STICKERS FOR THE UPPER BUNDLE SHOULD BE LOCATED IN LINE WITH THE FOAM STICKERS FOR WITH THE LOWER BUNDLE (SEE FIGURE 3, BELOW).

5.5 BUNDLES SHOULD BE FIRMLY TIED OR WEIGHTED DOWN WHEN BROKEN OPEN FOR USE.

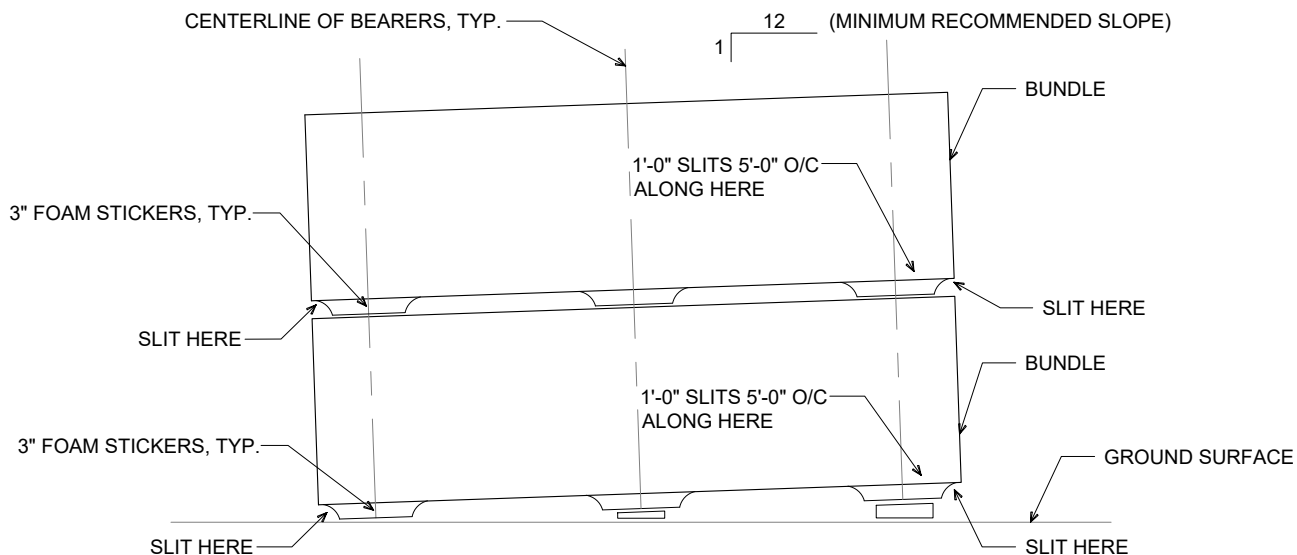

FIGURE 3

SHEET:

4 OF 11

DATE:

06/14/22

DRAWN BY:

MMF

fiRE WALL PANELS GENERAL INSTALLATION GUIDE

6.0 ACCESSORIES AND AUXILIARY ITEMS

- 6.1 DUE CARE SHOULD BE AFFORDED TO THE HANDLING AND STORAGE OF SMALL ITEMS (E.G. FLASHINGS, FASTENERS, SEALANTS, ETC.) THAT ARRIVE ON SITE FOR INCLUSION IN THE WORK.
- 6.2 COVER ALL PALLET CRATES AND/OR BOXES TO PROTECT MATERIALS FROM WEATHER BUT ALLOW FOR ADEQUATE VENTILATION TO PREVENT COLLECTION OF CONDENSATION.

7.0 SUPPORTING STEEL

- 7.1 FOR QUALITY PANEL INSTALLATION, THE PANEL CONTRACTOR SHALL EXAMINE THE ALIGNMENT OF THE SUPPORT STEEL BEFORE INSTALLATION OF THE WALL PANELS. THE STEEL SHALL BE ALIGNED TO PER THE TOLERANCES ESTABLISHED IN THE AISC CODE OF STANDARD PRACTICE, SECTION 7, AND THE SUPPLEMENT MODIFICATION CONTROL SECTION 7.11.3, ADJUSTABLE ITEMS. THE MAXIMUM DEVIATION OF STEEL ALIGNMENT SHOULD BE LIMITED TO $-0, + \frac{3}{16}$ " FROM THE CONTROL WITH AN $\frac{1}{8}$ " MAXIMUM CHANGE IN DEVIATION FOR ANY MEMBER OF ANY 10'-0" RUN OF PANEL.
- 7.2 ANY VARIANCE(S) FROM THESE TOLERANCES CAN AFFECT BOTH PERFORMANCE AND AESTHETICS AND MUST BE REPORTED TO THE ARCHITECT AND GENERAL CONTRACTOR AND CORRECTED BY THE GENERAL CONTRACTOR OR ACCEPTED, IN WRITING, BY THE ARCHITECT BEFORE PANEL INSTALLATION PROCEEDS.
- 7.3 THE FACE(S) OF ALL SUPPORT MEMBERS TO WHICH THE PANEL IS ATTACHED MUST BE IN THE SAME VERTICAL PLANE, FLAT, AND FREE OF OBSTRUCTIONS SUCH AS WELD MARKS, BOLTS, OR RIVET HEADS. INSTALLATION OF THE PANELS SHOULD PROCEED ONLY IF THE ALIGNMENT OF SUPPORT MEMBERS MEETS THE TOLERANCES ESTABLISHED IN THE CONTRACT DOCUMENTS.

8.0 VERTICAL LOADING ON PANELS

- 8.1 TO PREVENT THE PANELS FROM TAKING VERTICAL LOADS, ATTACHMENTS TO RIGID SUPPORTS MUST HAVE MEANS OF ALLOWING THE STRUCTURE TO DEFLECT WITHOUT DAMAGING THE INSULATED PANELS.
- 8.2 PANEL SHALL ALWAYS BE ATTACHED TO SUPPORT MEMBERS RUNNING PERPENDICULAR TO THE PANEL LENGTH. NEVER ATTACH PANELS DIRECTLY TO A STRUCTURAL (PRIMARY) SUPPORT MEMBER, E.G. COLUMN FLANGE.

9.0 PROTECTIVE PLASTIC FILM

- 9.1 ALL WEATHER INSULATED PANELS AND METAL TRIMS HAVE A TEMPORARY PROTECTIVE PLASTIC FILM. THIS PLASTIC FILM HELPS PREVENT DAMAGE DURING SHIPPING AND HANDLING.
- 9.2 THIS PROTECTIVE PLASTIC FILM IS NOT TO BE REMOVED UNTIL PANELS AND METAL TRIMS ARE READY FOR ERECTION.
- 9.3 PROTECTIVE PLASTIC FILM SHALL NOT BE EXPOSED TO DIRECT SUN FOR MORE THAN 48 HOURS AS THIS MAY CAUSE THE PLASTIC FILM TO BOND TO THE METAL PANEL FACE AND MAY BECOME MORE DIFFICULT TO REMOVE. ADDITIONALLY, PROLONGED EXPOSURE TO TEMPERATURES ABOVE 80° F IS NOT RECOMMENDED AS THIS MAY CAUSE THE PEEL COAT TO LEAVE AN ADHESIVE RESIDUE ON THE PANEL FACING(S).

NOTE: SEE SECTION 5.0 FOR INSTRUCTIONS ON PROPER STORAGE.

- 9.4 THE BEST WAY TO REMOVE THE PROTECTIVE PLASTIC FILM IS TO START AT A PANEL CORNER AND PEEL OFF AT A 45° ANGLE (SEE FIGURE 4, BELOW).
- 9.5 THE PLASTIC FILM MUST BE REMOVED FROM BOTH PANEL FACES AND METAL TRIMS (IF APPLICABLE).
- 9.6 ANY RESIDUE ON THE METAL FACE(S) FROM THE PLASTIC FILM WILL WEATHER OFF NATURALLY. IF DESIRED, IT CAN BE REMOVED USING A SOFT CLOTH AND WATER. IT MAY BE NECESSARY TO USE A CITRUS-BASED CLEANING SOLUTION ADDED TO THE WATER IN A SUFFICIENT DILUTION RATIO TO EFFECT COMPLETE REMOVAL OF THE ADHESIVE.

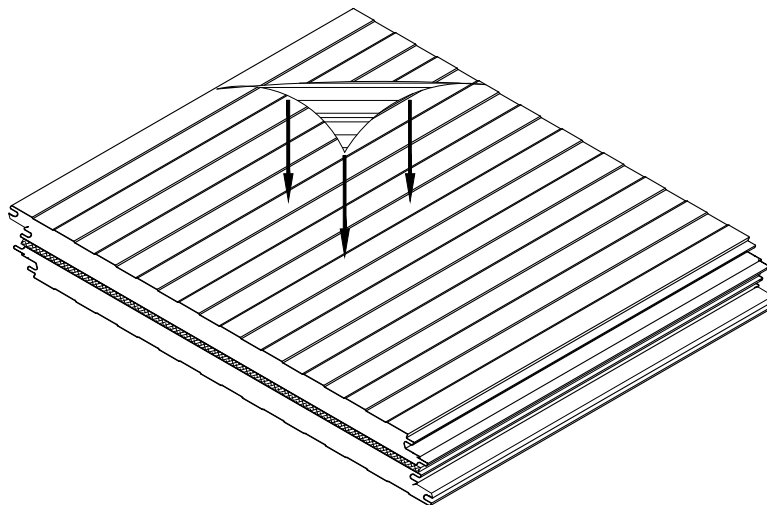

FIGURE 4

SHEET:

5 OF 11

DATE:

06/14/22

DRAWN BY:

MMF

fiRe WALL PANELS GENERAL INSTALLATION GUIDE

10.0 ACCESSORIES, TRIM, SEALANTS, ETC.

- 10.1 EXTREME CARE SHOULD BE TAKEN WHEN UNLOADING AND STORING THE FASTENERS, SEALANTS, ETC. IT IS IMPORTANT TO GUARD AGAINST DAMAGE OR MISPLACEMENT OF THE ACCESSORIES.
- 10.2 ALL ACCESSORIES MUST BE STORED IN A COVERED LOCATION ON THE JOBSITE AND NOT EXPOSED TO THE ELEMENTS.

11.0 PANEL CUTTING PROCEDURES

- 11.1 PANELS MAY BE CUT PRIOR TO INSTALLATION OR CUT IN-PLACE. ALL WEATHER INSULATED PANELS RECOMMENDS CUTTING THE PANELS PRIOR TO INSTALLATION TO MINIMIZE PANEL DAMAGE AND TO ENSURE A GOOD FIT.
- 11.2 ALL WEATHER INSULATED PANELS RECOMMENDS USING A CIRCULAR SAW WITH AN 8" DIAMETER, 40 TOOTH CARBIDE BLADE.
- 11.3 TO PERFORM A GOOD CUT, FOLLOW STEPS 1 THROUGH 4 SHOWN BELOW. IF THE PANEL THICKNESS IS GREATER THAN THE SAW'S BLADE RADIUS, CUTTING SHOULD BE DONE IN TWO STEPS, CUTTING ONE SIDE AT A TIME; FOLLOW STEPS 1 THROUGH 6.
1. MEASURE THE AREA TO CUT AND MARK A LINE ON THE PANEL SURFACE.
 2. USE ADHESIVE TAPE ON BOTH SIDES OF THE CUTTING LINE TO PROTECT PANEL SURFACE.
 3. RECHECK MEASUREMENTS AND PROCEED WITH CUTTING OPERATION.
 4. CLEAN OFF ANY METAL CHIPS LEFT ON PANEL AFTER CUTTING PROCEDURE. ANY METAL CHIPS ON THE FOAM CAN BE REMOVED BY HAND.
 5. IF NECESSARY, TURN PANEL OVER AND FOLLOW STEPS 1 THROUGH 4 FOR THE OTHER SIDE OF THE PANEL.
 6. FILE OR SAND OFF ANY BURRS ON THE METAL AFTER CUTTING. THE PANEL IS NOW READY FOR INSTALLATION. THE INSTALLER MUST CONSIDER THE APPLICATION OF A CONTINUOUS BEAD OF SEALANT AND, IF NECESSARY, THE CUTTING OF THERMAL BREAKS PRIOR TO INSTALLATION; SUCH TASKS SHALL BE DONE ON THE GROUND.
- NOTE:** DO NOT USE A RECIPROCATING SAW AS IT MAY CREATE EGE DELAMINATION BY TEARING THE FACINGS FROM THE FOAM CORE, ESPECIALLY IN COLDER CLIMATE CONDITIONS. ADDITIONALLY, FRICTION BETWEEN THE CUTTING BLADE AND THE PANEL CREATES HEAT AND MAY DAMAGE THE PAINTED SURFACE OF THE PANEL.

12.0 THERMAL BREAKS

- 12.1 THERMAL BREAKS (CUTTING THE INTERIOR METAL SKIN) FOR COLD-STORAGE APPLICATIONS ARE NECESSARY TO STOP TEMPERATURE CONDUCTIVITY IN THE PANEL. CONSULT YOUR ALL WEATHER INSULATED PANELS REPRESENTATIVE FOR SPECIFIC DETAIL(S) AND/OR REVIEW THE DETAILS IN THE ALL WEATHER INSULATED PANELS SHOP DRAWINGS.

13.0 CAULKING / SEALANT PLACEMENT

- 13.1 APPLY CAULKING TO PANEL JOINERY AS SHOWN ON THE SHOP DRAWING DETAILS TO PROVIDE A BARRIER AGAINST VAPOR AND AIR INFILTRATION. CAULKING IS BEST APPLIED WHILE PANELS ARE LYING FLAT. APPLY BEADS OF CAULK IMMEDIATELY PRIOR TO ENGAGING PANELS.
- 13.2 CAULKING SHOULD BE APPLIED AROUND PANEL OPENINGS AND SUPPORT STEEL WHERE PANEL ENDS OCCUR TO DEVELOP VAPOR AND AIR INFILTRATION SEALS. THE BEADS OF CAULK ON THE SUPPORT STEEL MUST BE MARRIED TO THE BEADS OF CAULK IN THE PANEL JOINT.

NOTE: SEE JOINT DETAIL(S) IN THE PROJECT SHOP DRAWINGS FOR JOB-SPECIFIC CAULKING INSTRUCTIONS.

NOTE: THE HIGH-TEMPERATURE SILICONE SEALANT HAS A TOOLING TIME OF 5-10 MINUTES AND TACK TIME OF 1 HOUR. PANELS SHOULD BE ENGAGED AS SOON AS POSSIBLE AFTER SEALANT PLACEMENT TO ENSURE PROPER ADHESION TO PANEL JOINERY. THE TONGUE AND GROOVE JOINT MAY ALSO BE DIFFICULT TO FULLY ENGAGE AS THE SEALANT CURES (SEE SECTION 15.2 FOR PROPER JOINT MODULATION).

- 13.3 ADEQUATE CAULKING AND SEALING OF PANELS AND TRIMS IS THE SOLE RESPONSIBILITY OF THE INSTALLING CONTRACTOR (CUSTOMER). ALL WEATHER INSULATED PANELS HIGHLY ADVISES PRE-INSTALLATION QUALITY CONTROL TESTING TO BE COMPLETED ON-SITE PRIOR TO COMMENCING WITH INSTALLATION TO ENSURE A COMPLETE SEALANT BRIDGE FROM METAL TO METAL.

14.0 CORNER INSTALLATION

- 14.1 PANELS ARE INSTALLED FROM LEFT TO RIGHT WHEN VIEWED FROM THE EXTERIOR.
- 14.2 INSTALL POLARFAST FASTENERS 1" (MINIMUM) INBOUND OF CUT LINE PRIOR TO FIELD-RIPPING THE PANEL. STARTER AND END PANELS SHOULD BE FIELD-CUT AS SHOWN (SEE FIGURE 5, BELOW).

NOTE: ALL WEATHER INSULATED PANELS MAY BE INSTALLED FROM RIGHT TO LEFT BY TURNING THE PANEL OVER. REMEMBER THAT THE FEMALE EDGE OF THE WALL PANEL IS ALWAYS THE LEADING EDGE WHEN USING THE HIDDEN FASTENERS.

SHEET:

6 OF 11

DATE:

06/14/22

DRAWN BY:

MMF

fiRe WALL PANELS GENERAL INSTALLATION GUIDE

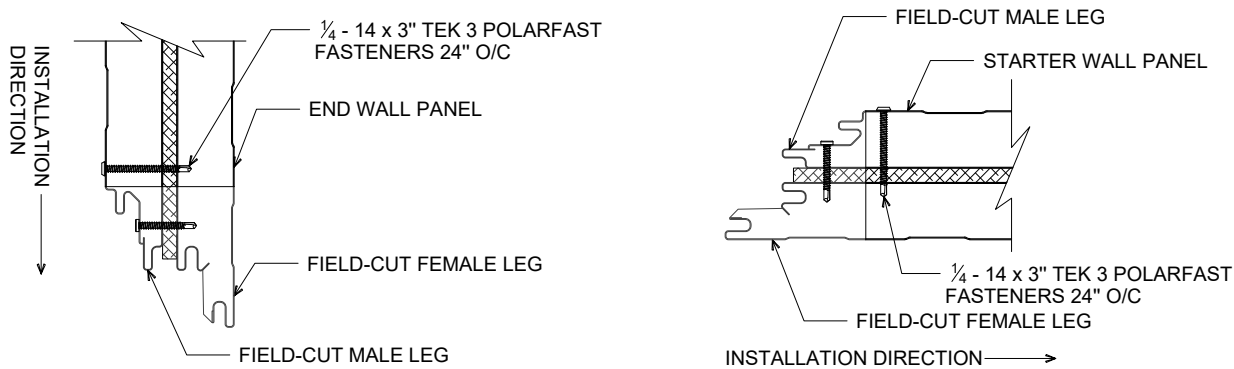

FIGURE 5

- 14.3 PLACE BOTTOM END OF PANEL ON BASE AND TILT TO VERTICAL POSITION. LONGER PANELS MAY REQUIRE THE USE OF A ROPE HOIST OR A PANEL LIFTING DEVICE SUCH AS A WOOD'S POWR-GRIP.
- 14.4 AFTER DRILLING OR CUTTING PANELS, ALWAYS REMOVE METAL CHIPS THAT HAVE FALLEN ON THE FLASHING OR PANELS TO PRECLUDE LATER DAMAGE.
- 14.5 POSITION STARTER PANEL IN PLACE AND THROUGH-FASTEN TO THE SUPPORT STEEL WITH #14 THROUGH FASTENER(S) AT EACH GIRT LINE. POSITION THE #14 THROUGH FASTENER(S) CLOSE ENOUGH TO THE PANEL EDGE SUCH THAT THEY ARE COVERED BY THE OUTSIDE CORNER TRIM. POSITION THE END OR OTHER STARTER PANEL IN PLACE AND THROUGH-FASTEN TO THE SUPPORT STEEL. CAULK AND FASTEN THE OUTSIDE CORNER TRIM TO THE WALL PANELS WITH COLOR-MATCHED SCREWS OR POP RIVETS AT 12" O.C. (UNLESS NOTED OTHERWISE ON THE PROJECT SHOP DRAWINGS) TO COMPLETE THE CORNER INSTALLATION.

NOTE: IF INSTALLING THE (OPTIONAL) INSIDE CORNER TRIM, FASTEN AT 12" O.C. WITH #10 x 3/4" PHILIP PAN HEAD FASTENERS BETWEEN GIRTS (UNLESS NOTED OTHERWISE ON THE PROJECT SHOP DRAWINGS).

15.0 WALL PANEL INSTALLATION

- 15.1 PLACE BOTTOM END OF PANEL ON BASE AND TILT TO VERTICAL POSITION. LONGER PANELS MAY REQUIRE THE USE OF A ROPE HOIST OR A PANEL LIFTING DEVICE SUCH AS A WOOD'S POWR-GRIP.

NOTE: ALL WEATHER INSULATED PANELS RECOMMENDS THE USE OF SUCTION LIFTERS, AS NEEDED, TO MAXIMIZE SAFETY AND MINIMIZE UNDUE MANUAL HANDLING.

THERMAL BOW: PRIOR TO INSTALLATION, PANELS MAY NEED TO BE PLACED IN A COVERED LOCATION TO PREVENT EXCESSIVE THERMAL BOW WHICH MAY HINDER PANEL ENGAGEMENT.

- 15.2 SLIDE PANEL FIRMLY INTO GROOVE OF THE PRECEDING PANEL USING FIRM, GRADUAL PRESSURE TO DRAW PANELS TOGETHER. DO NOT POUND INTO PLACE. DO NOT USE LOCALIZED FORCES WHICH MAY DAMAGE PANELS. TO ENSURE A CONSISTENT JOINT MODULATION, PLASTIC SPACERS (3/32" MAX.) MAY BE USED AT THE EXTERIOR SIDE AS PANEL ARE BEING ENGAGED (NON-COLD STORAGE APPLICATIONS ONLY). PLUMB AND SQUARE EACH PANEL BEFORE INSTALLING FASTENERS.

MODULATION: PANELS WILL NOT MODULATE TO THE EXACT NET OF THE INDIVIDUAL FACE DIMENSION. THERE WILL ALWAYS BE SOME PANEL GROWTH OR "CREEP" WHICH MUST BE CONSIDERED PRIOR TO INSTALLATION.

- 15.3 PREVENT WATER INTRUSION: IF WALL PANELS ARE LEFT EXPOSED AT PARAPET OR EAVE CONDITIONS AFTER INSTALLATION, VERTICAL INTERLOCKING JOINTS WILL BE SUSCEPTIBLE TO WATER INTRUSION. PANELS AT THESE CONDITIONS MUST BE ADEQUATELY PROTECTED PRIOR TO TRIM OUT AND WEATHER SEALING TO AVOID WATER GETTING TRAPPED IN THE VERTICAL JOINTS AND DAMAGE TO THE GYPSUM LAYER.
- 15.4 HIDDEN CLIP STYLE WALL PANELS (SEE BELOW FOR AVAILABLE PANEL TYPES) ARE ATTACHED TO SUPPORT STEEL USING WC-01 CLIP AND FASTENER ASSEMBLIES.

- 15.5 TO INSTALL FASTENER, PRE-DRILL (AS REQUIRED) USING THE APPROPRIATE DRILL SIZE. INSERT FASTENER THROUGH CLIP AND TIGHTEN DOWN UNTIL CLIP AND FASTENER ASSEMBLY ARE SNUG. FASTENER REQUIREMENTS ARE BASED ON GIVEN DESIGN LOADS. PANELS ARE TO BE FASTENED PER SHOP DRAWING DETAILS AND CALCULATED FASTENER SCHEDULE PROVIDED ON ALL WEATHER INSULATED PANEL SHOP DRAWING PROJECTS. USE A STANDARD 0 TO 600 RPM VARIABLE SPEED SCREW GUN WITH 4 TO 5 AMPS AND A POSITIVE CLUTCH OR DEPTH LOCATING NOSE PIECE TO DRIVE FASTENERS. DO NOT USE IMPACT TYPE GUNS. DO NOT OVER-TIGHTEN.

NOTE: IF A FACTORY-APPLIED 1/4-14 2" FASTENER IS PRESENT AT THE LOCATION OF WC-01 CLIP PLACEMENT, REMOVE FASTENER WITH #2 SQUARE DRIVE BIT INCLUDED WITH THE ACCESSORIES. REPLACE FACTORY-APPLIED FASTENER WITH WC-01 CLIP ASSEMBLY AND 1/4-14 5" FASTENERS.

- 15.6 TRIM(S) SHOWN IN THE ALL WEATHER INSULATED PANELS SHOP DRAWINGS SHOULD BE USED WHERE PANELS TERMINATE SUCH AS HEAD, SILL, BASE, BUTT, ETC. CONDITIONS. COVER EXPOSED EDGES AS SOON AS POSSIBLE.

fiRe WALL PANELS
GENERAL INSTALLATION GUIDE

15.7 IN WET OR HIGH HUMIDITY CLIMATES, IT IS ESSENTIAL THAT EXPOSED PANEL AND TRIM CUT ENDS BE FIELD-COATED WITH A CLEAR ACRYLIC PAINT FINISH TO HELP PREVENT RUSTING.

16.0 MISCELLANEOUS INFORMATION

16.1 TO PREVENT GALVANIC ACTION, ISOLATE ANY ALUMINUM TRIM SURFACE(S) FROM SURFACE OF PANEL SUPPORT STEEL USING ONE OF THE FOLLOWING METHODS:

- 1) AN APPROVED SEALANT OR SEALANT TAPE.
- 2) A NON-ABSORBENT GASKET.
- 3) DUCT TAPE OR EQUIVALENT TYPE TAPE.
- 4) PAINT THE INCOMPATIBLE METAL WITH A COATING OF HEAVY BODIED BITUMINOUS PAINT.

16.2 GAS BUBBLES ON FOAM PANELS ARE AN INDUSTRY-WIDE, SPORADIC PROBLEM. IF THEY OCCUR ON THIS PROJECT, THEY CAN EASILY BE REPAIRED BY DRILLING A $\frac{1}{8}$ " DIAMETER BY $1\frac{3}{4}$ " DEEP HOLE NEAR THE BOTTOM OF THE GAS BUBBLE IN THE EXTERIOR METAL FACING TO ALLOW THE TRAPPED GAS TO BE RELEASED. THE REPAIR IS COMPLETED BY APPLYING A SMALL AMOUNT OF CLEAR ACRYLIC TOUCH-UP PAINT TO THE RAW EDGE OF THE DRILL HOLE. GAS BUBBLES SHOULD BE REPAIRED AS SOON AS POSSIBLE AS THEY WILL CONTINUE TO GROW UNTIL CORRECTED. GAS BUBBLES ARE NOT A CAUSE FOR REJECTION OF THE PANEL(S).

16.3 ALL WEATHER INSULATED PANELS MAKES EVERY EFFORT TO SEPARATE STANDARD COLOR COIL LOTS BY PROJECT PRODUCTION RUNS AND/OR BUILDING AREAS (ELEVATIONS). SAME COLOR AND FINISH SYSTEMS FROM DIFFERENT COIL COAT LOTS MAY BE WITHIN INDUSTRY QC TOLERANCE, BUT MAY ALSO BE NOTICEABLE ON A FULL SCALE WALL IF PANELS FROM DIFFERENT LOTS ARE MIXED. ALWAYS USE PANEL BUNDLES MARKED FOR THE SPECIFIC AREA (WALL ELEVATION) TO ENSURE ACCEPTABLE PANEL TO PANEL COLOR/FINISH MATCH.

16.4 FLATNESS: OIL CANNING OR "SCOLLOPING" IS AN INHERENT CONDITION OF LIGHT GAUGE COLD-FORMED METAL PRODUCTS, PARTICULARLY THOSE WITH BROAD, FLAT AREAS. OIL CANNING MAY BE AN AESTHETIC ISSUE, PARTICULARLY IN CONDITIONS OF ANGLED LIGHT AND DOES NOT AFFECT THE STRUCTURAL INTEGRITY OR THERMAL PERFORMANCE OF THE PANELS. AWIP HAS ADOPTED FLATNESS TOLERANCE PARAMETERS BASED ON INDUSTRY STANDARDS AND PROVIDED BY THEIR COIL STEEL SUPPLIERS. THEREFORE, OIL CANNING AND PERCEIVED WAVINESS THAT ARE WITHIN AWIP QC TOLERANCES ARE NOT GROUNDS FOR PANEL OR TRIM REJECTION.

17.0 EXPOSURE TO HEAT OR FLAME

17.1 ALTHOUGH ALL WEATHER INSULATED PANELS fire SERIES PANELS ARE ACCEPTABLE FOR USE IN NON-COMBUSTIBLE BUILDING AND ONE-HOUR FIRE RATED ASSEMBLIES IN ACCORDANCE WITH THE INTERNATIONAL BUILDING CODE (IBC) AND HAVE BEEN EXHAUSTIVELY TESTED FOR FIRE RESISTIVITY BASED ON THEIR END USE, THEY ARE NOT NON-COMBUSTIBLE IN AND OF THEMSELVES. THE PANELS ARE INTENDED TO CONTAIN A FIRE FOR A DURATION OF ONE HOUR IN THE CASE OF EMERGENCIES. THEREFORE, THEY SHALL NOT BE EXPOSED TO EXTREMELY HIGH TEMPERATURES OR DIRECT FLAME AT ANY TIME. SIMPLY STATED, DO NOT USE A WELDING TORCH ON OR NEAR fire INSULATED PANELS ANY MORE THAN YOU WOULD ON A WOODEN BUILDING ASSEMBLY. REFER TO PANEL FIRE TEST INFORMATION ON IGNITION, HEAT OF COMBUSTION, SURFACE BURNING AND STRUCTURAL INTEGRITY.

18.0 CLEANING PANELS

18.1 AFTER INSTALLATION, SURFACES MUST BE CLEANED TO REMOVE ANY METAL CHIPS TO PREVENT ANY POSSIBLE OXIDATION. A WET, SOFT CLOTH IS RECOMMENDED.

19.0 MAINTENANCE

19.1 PROPER INSTALLATION AND MAINTENANCE ARE EXTREMELY IMPORTANT TO OBTAIN THE BEST PERFORMANCE AND APPEARANCE FROM THE INSULATED PANELS.

19.2 DIRT, OIL, GREASE, FINGERPRINTS OR ANY OTHER KIND OF CONTAMINANT MUST BE COMPLETELY REMOVED WHEN THE INSTALLATION IS FINISHED TO MAXIMIZE COATING(S) PERFORMANCE.

19.3 THE BUILDING WILL REQUIRE PERIODIC MAINTENANCE ACCORDING TO SITE CONDITIONS (U.V EXPOSURE, DIRT, SMOKE, CORROSIVE ATMOSPHERE, ETC). IF FURTHER ASSISTANCE IS REQUIRED, PLEASE CONSULT ALL WEATHER INSULATED PANELS' TECHNICAL DEPARTMENT.

19.4 TO REMOVE SUPERFICIAL OXIDATION AND TOUGH STAINS, IT IS RECOMMENDED TO USE A REGULAR HOUSEHOLD CLEANER FOLLOWED BY A THOROUGH RINSING. WIRE BRUSHES AND/OR ABRASIVE MATERIAL WILL DAMAGE THE PAINTED COATING.

19.5 IF "TOUCH-UP" PAINT IS REQUIRED, CONTACT ALL WEATHER INSULATED PANELS TO OBTAIN A PAINT CHIP FOR COLOR-MATCHING.

19.6 SINCE METAL-FACED INSULATED PANELS ARE A MODULAR SYSTEM, THEY REQUIRE JOINT AND INTERSECTING CAULKING TO MINIMIZE POTENTIAL LEAKS IN THE BUILDING ENVELOPE. THE FLEXIBLE SEALANT MATERIALS TYPICALLY USED ARE GUN-GRADE OR RIBBON-TYPE AND EITHER BUTYLOID, SILICONE, OR URETHANE-BASED, DEPENDING ON THE SPECIFIC APPLICATION. IT IS ESSENTIAL TO INSPECT CRITICAL AREAS USED TO COMPLETE THE BUILDING ENVELOPE EVERY 24 MONTHS AFTER THE FIRST 60 MONTHS IN-PLACE. OVER TIME, SEALANTS WILL SHRINK, CRACK, AND LOSE ADHESION WHEN SUBJECTED TO HEAT AND COLD, FREEZE / THAW, EXPANDING / CONTRACTING METAL, MOISTURE, AND CHEMICAL CONTAMINANTS. SEALANTS CAN BE REMOVED AND REPLACED WHERE PRACTICAL OR AREAS CAN BE FACE-SEALED FROM THE INTERIOR. FOR SPECIFIC RECOMMENDATIONS OF SEALANT TYPE(S) AND / OR APPLICATION(S), CONTACT YOUR ALL WEATHER INSULATED PANELS REPRESENTATIVE.

SHEET:

8 OF 11

DATE:

06/14/22

DRAWN BY:

MMF

fire WALL PANELS GENERAL INSTALLATION GUIDE

WALL PANEL PROFILES

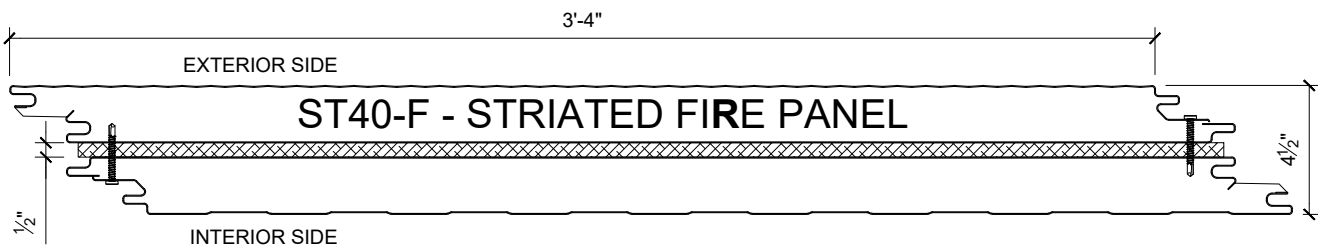
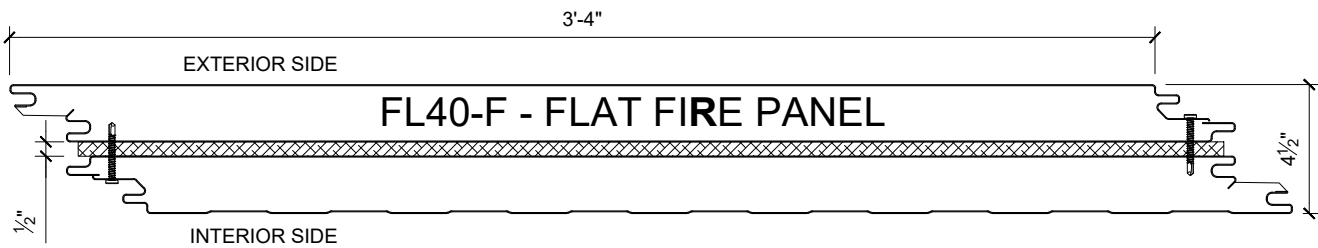
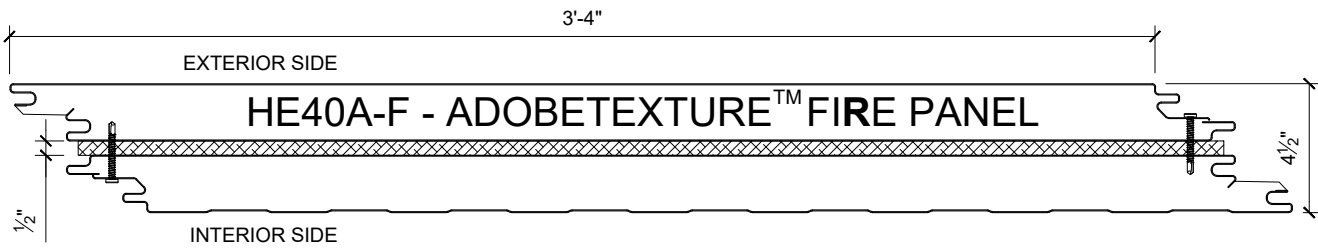
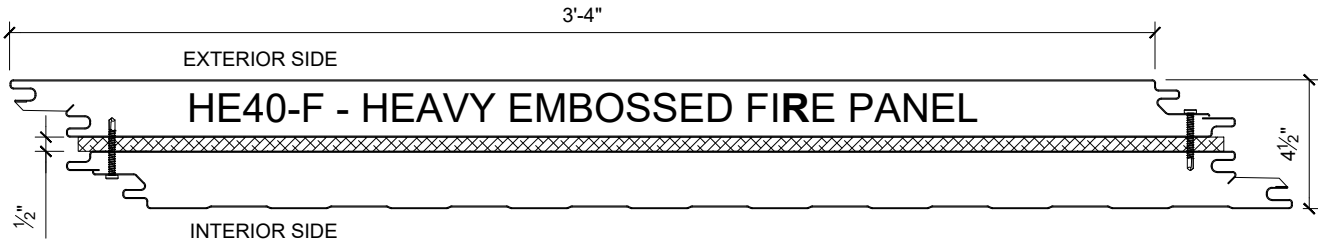
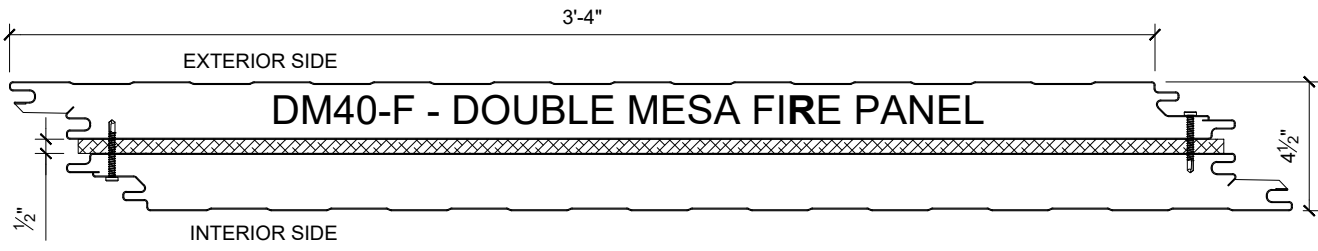

SHEET: 9 OF 11
DATE: 06/14/22
DRAWN BY: MMF

fire WALL PANELS GENERAL INSTALLATION GUIDE

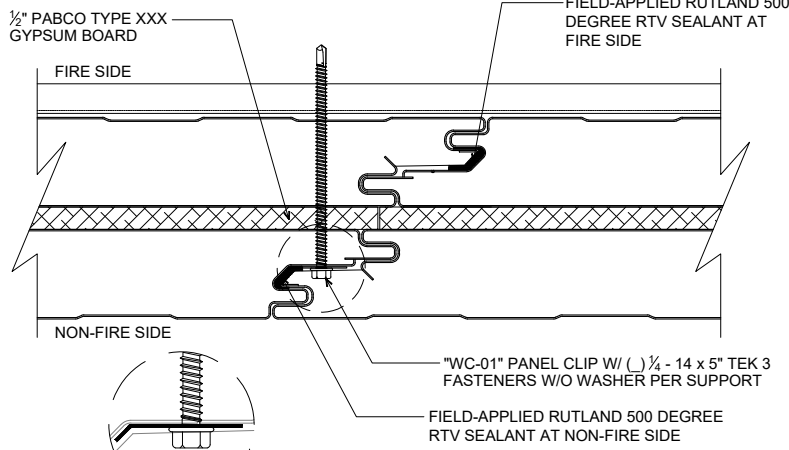

"WC-01" ORIENTATION

PANEL JOINT FASTENING
(PLAN VIEW - EXTERIOR WALL)

NOTE: FILL NON-FIRE SIDE CAVITY AND FIRE SIDE CAVITY CONTINUOUSLY WITH 1/2" DIAMETER BEAD (APPROXIMATE) OF RTV SEALANT (DO NOT UNDER-FILL).

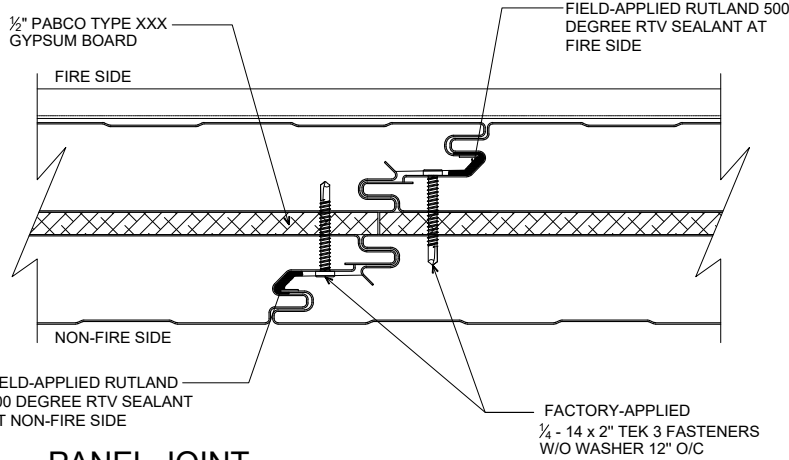

PANEL JOINT
(PLAN VIEW - EXTERIOR WALL)

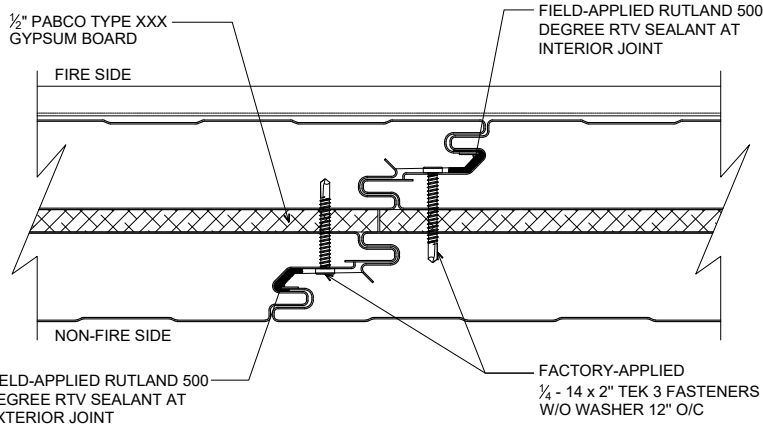

PANEL JOINT
(PLAN VIEW - PARTITION WALL)

NOTE: FASTENING SCHEDULE MAY VARY DEPENDING ON SPECIFIC APPLICATION.

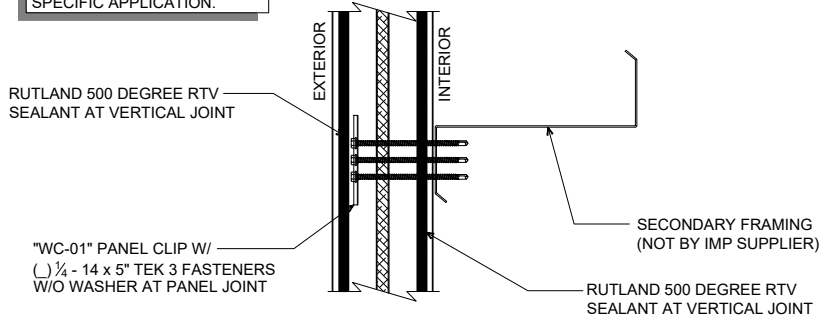

INTERMEDIATE WALL SUPPORT
(SECTION VIEW - EXTERIOR WALL)

SHEET: DATE: 06/14/22

10 OF 11

DRAWN BY: MMF

fiRE WALL PANELS
GENERAL INSTALLATION GUIDE

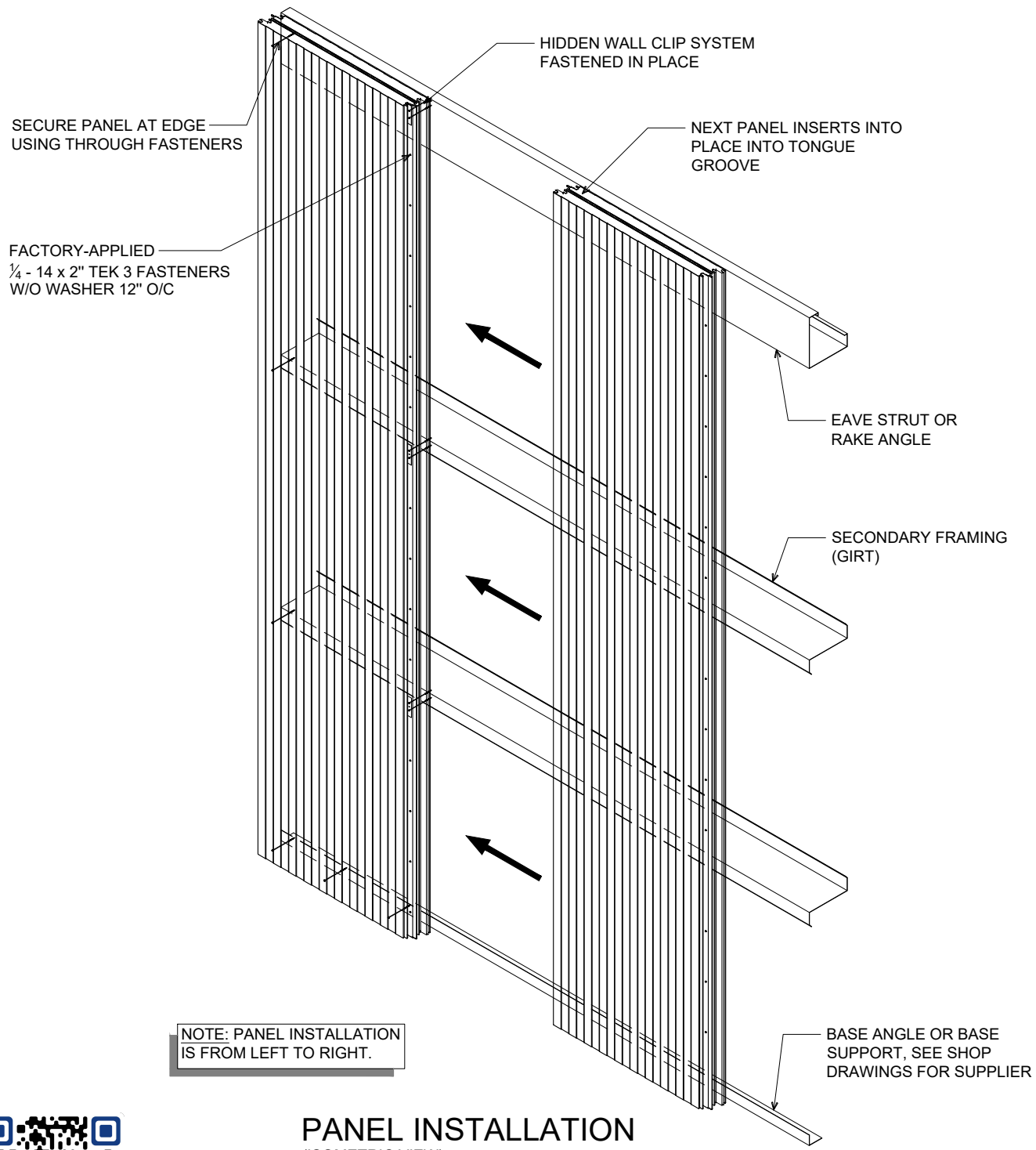

NOTE: PANEL INSTALLATION IS FROM LEFT TO RIGHT.

PANEL INSTALLATION
(ISOMETRIC VIEW)



Scan for the most current product information

©2023 All Weather Insulated Panels (AWIP) - All rights reserved. In accordance with ongoing efforts to improve our products and their performance, AWIP reserves the right to change without notice the specifications herein. These contents are for general information only and are not intended to serve as any type of advice. Every effort is made to ensure the accuracy of the information included herein and it is believed to be accurate and reliable as of the date of publication. AWIP does not warrant or represent the accuracy or reliability of any information included in this publication. Any reliance on any information without consultation with AWIP or a duly authorized representative shall be at the user's own risk.

fiRe WALL PANELS
GENERAL INSTALLATION GUIDE

